

INSTALLATION GUIDE FOR THE E-DCLM-6 DC Voltage and Current Monitor



INTRODUCTION

The NTI E-DCLM-6 DC Voltage and Current Monitor monitors up to six DC voltage sources and current levels when connected to an E-16D, E-5D or E-2D Server Environment Monitoring System(SYSTEM). The E-DCLM-6 will measure DC voltage between -60 to +60VDC. Current measurements can be taken on DC loads and with the use of hall effect sensors (sold separately). When connected to a SYSTEM via 18-24AWG CAT5/5e/6 cable (up to 1,000 feet away), the voltage and/or current draw(s) can be monitored and the SYSTEM can be configured to alert users as to variations in the voltage and current levels.

Features:

- Detects and monitors up to six DC voltages (-60 to +60VDC)
- Monitors up to 6 DC Current measurements using hall-effect transducers (sold separately)
- No Current measurement limit (hall-effect transducer dependent)
- 2 and 4-position screw-terminal connections
- Supports 18-24AWG CAT5/5e/6 cable up to 1,000 ft. (305M) (not included)
- Includes Mounting Ears
- CE certified and RoHS compliant
- Powered by E-2D/5D/16D (requires firmware version 2.37 or later)
 - Absolute maximum input voltage range for external power source (if needed)- 10.8VDC to 16.5VDC
 - Optional 12VDC power supply sold separately
- Dimensions WxDxH (in): 6.8x3.0x1.75
- Accuracy and range are transducer-dependent (sold separately).
- Compatible with E-FSC Fiber Converter/Extender
 - Use to extend sensor up to 1.2 miles (2km) from the ENVIROMUX unit.

Note: The E-xD must be running firmware version 2.37 or later in order to use the E-DCLM-6 with it. Refer to the E-xD manual for firmware upgrade instructions as needed.

INSTALLATION

Mount the E-DCLM-6 using the mounting ears provided. To use the ears, remove the screws securing the ears to the rear of the E-DCLM-6, turn the ears around, and reapply the screws.

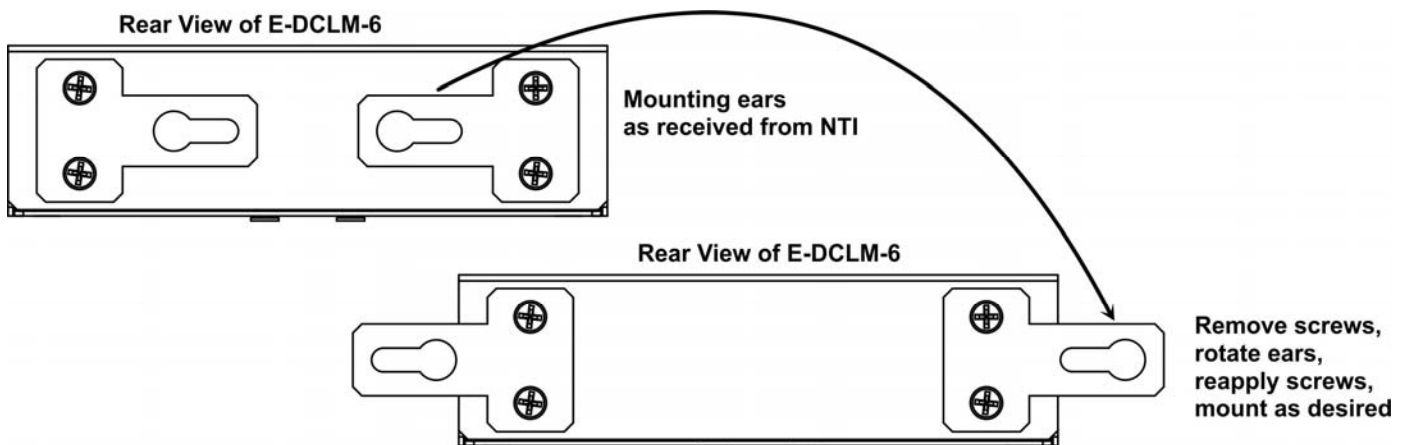

To mount multiple E-DCLM-6 in close proximity to the E-16D, install an extension rail kit (NTI E-RL-16D - sold separately) and mount E-DCLM-6 as seen in the illustration below.

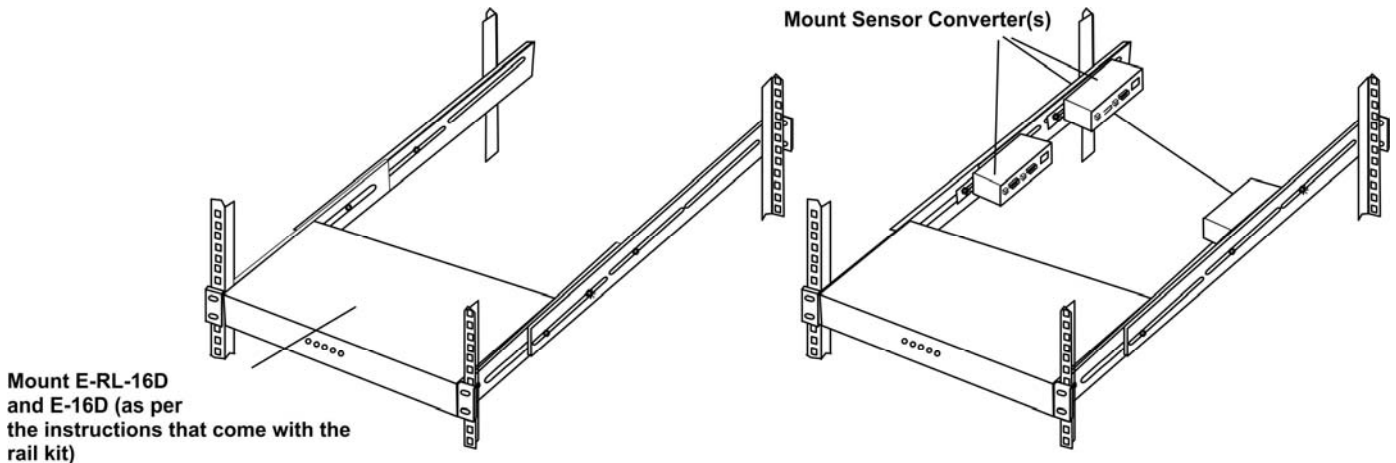

POWER CONNECTION- Using Connected CATx cable

The E-DCLM-6 may require more power (at 12VDC) than can be supplied by the RJ45 Sensor ports on the E-16D/5D/2D.

The E-DCLM-6 alone (without hall effect sensors connected) draws 34mA. Each hall effect sensor can require as much as 26mA. The E-DCLM-6 may draw up to 190mA of current when 6 hall effect sensors are connected.

- Each complete row of RJ45 sensors on the E-16D will support up to **500mA** of current load.
- The row of five RJ45 sensors on the E-5D will support up to **500mA** of current load.
- The two RJ45 sensors on the E-2D will support up to **200mA** of current load.

When your combination of attached sensors that operate at 12VDC restricts the amount of power that is available for the E-DCLM-6, the 12VDC Power Jack will need to be used. (Many sensors operate at 5VDC and do not need to be considered in this calculation.)

Note: If your CATx cable is longer than 50 feet, you must use the 12VDC Power Jack to power the E-DCLM-6.

POWER CONNECTION- Using 12VDC Power Jack

A 12VDC power jack and 7 foot power pigtail cable is supplied to enable easy connection of the E-DCLM-6 to the AUX PWR connection terminals on your system (E-2D, -5D and -16D as directed on the next page). If these terminals are already in use and sufficient remaining power capacity is not available from them (that is, they are in use to power other sensors), a 12VDC AC adapter can be purchased-sold separately (NTI # PS4235 + Country-specific power cord-).

The "AUX PWR" terminals for the E-2D and E-5D are rated to support up to 500mA, so connection of an E-DCLM-6 with all 6 hall effect sensors can be supported without external power supply.

Note: The "AUX PWR" terminals on the E-16D can only be used to power the E-DCLM-6 when a maximum of 4 hall effect sensors are used (150mA max.).

If the DC power jack is being used to power the E-DCLM-6, then all current demand is placed on the pigtail or power supply providing that power. Power requirements are provided by **EITHER** the CATx cable connecting the E-DCLM-6 to the ENVIROMUX System, **OR** by the DC power cord plugged into the jack.

Power requirements are **not shared** by the two connection methods.

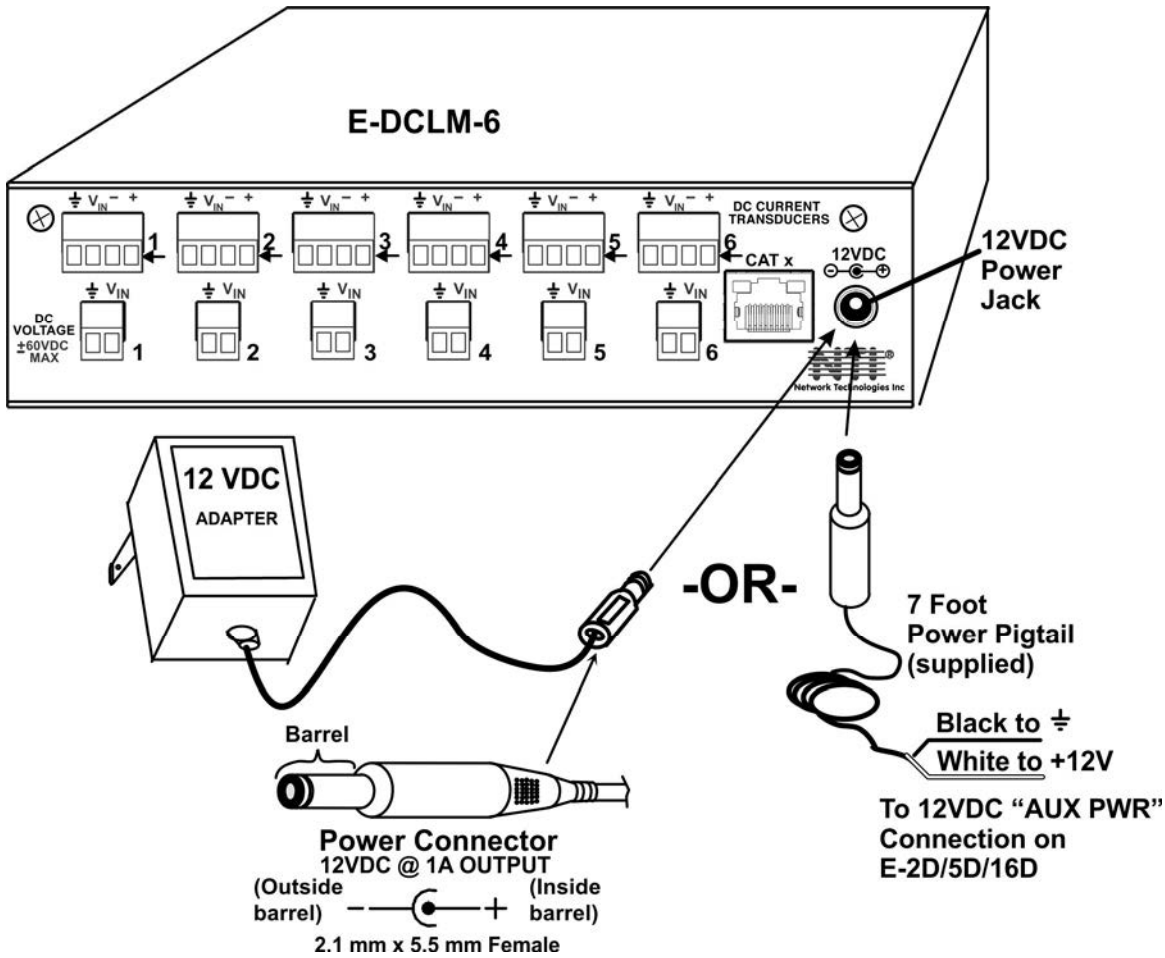

**AUX POWER TERMINALS
ON E-16D**

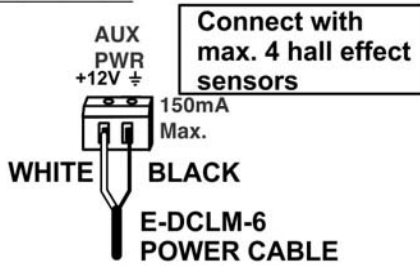

**AUX POWER TERMINALS
ON E-5D**

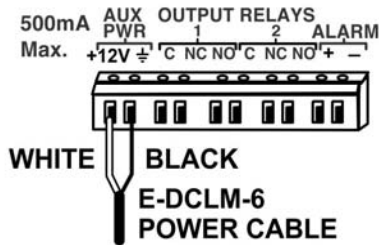

**AUX POWER TERMINALS
ON E-2D**

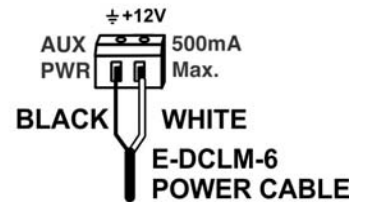

MONITORING CONNECTIONS

Note: To prevent damage to the voltage source or the Sensor Adapter proper polarity must be observed when making connections.

1. At the "DC VOLTAGE" terminal block, connect a -60 to +60VDC voltage source to be monitored to the "Vin" and "⊥" (earth ground) connections using the removable terminal block.
2. If current sensing is desired, install a hall effect sensor to the DC circuit to be monitored. Then connect the supplied 4-wire cable to the sensor. Connect the 4 wires at the end of the cable to a set of DC CURRENT TRANSDUCER terminals on the E-DCLM-6.

Note: The wire connection terminal block is easily removed from the Sensor Adapter for convenient wire termination.

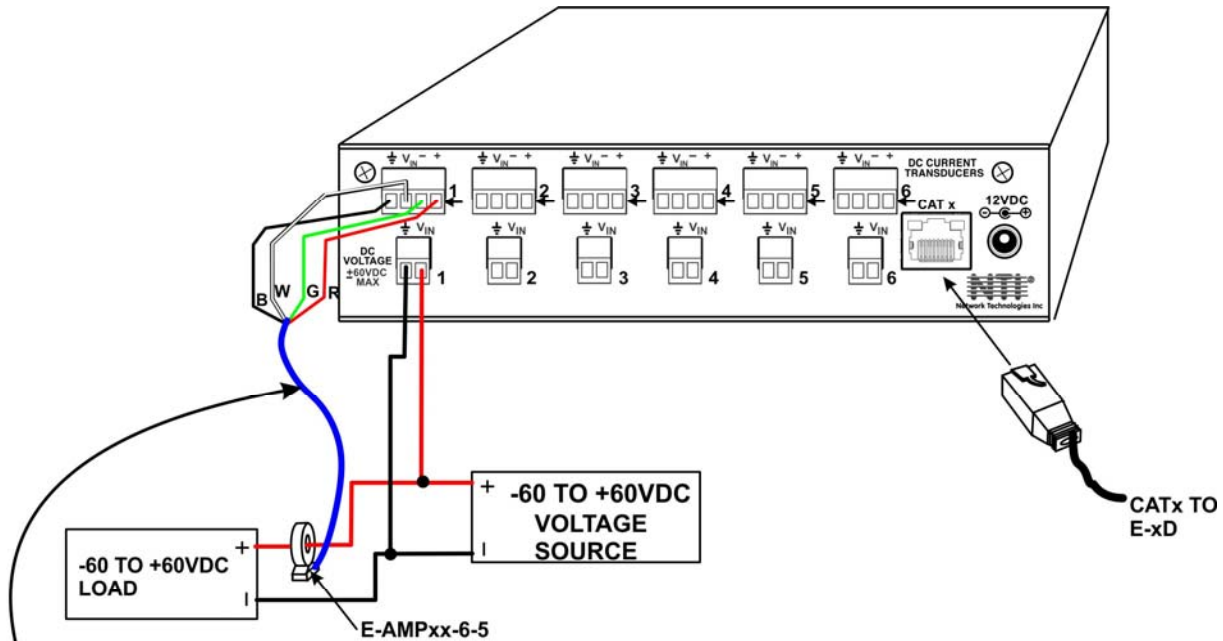

7 Foot cable provided. Cable can be extended to up to 1000 foot length with 22AWG stranded wire using the crimp-on wire splices supplied with the E-AMPxx-6-5, E-AMPxx-SC21, or E-AMPxx-SC12.

TIP: A single hall effect sensor can be used to measure current at different ranges. By passing a wire through the sensor loop repeatedly (looping the wire around), the range of the sensor will be divided by the number of times the wire passes through. For a 100A sensor, for example, two passes will reduce it by 100/2 (range of 0-50A), three passes will reduce it by 100/3 (range of 0-33A), and so on. See example below. If you need to increase the sensitivity of your sensor, this is a way to do so.

100A Hall Effect Sensor

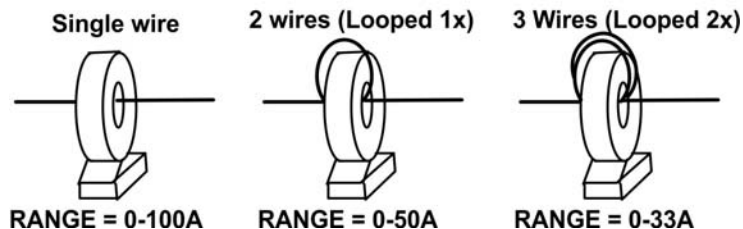

Installation Note: Hall Effect sensors can be rated AC Current-only, DC Current-only, or AC/DC current compatible. Sensors rated for DC current will include a directional current flow arrow either on the label or on the body of the sensor, indicating that current flowing in that direction will be reported by the sensor as positive current flow. When installing a hall effect sensor to a DC circuit, you will want to install it oriented such that the arrow points in the direction you want represented as positive current flow on the status page for that sensor.



Positive current flow indicator

Note: When placing a split core hall effect sensor (i.e. E-AMP100-SC12) around a conductor, make sure the sensor core is large enough to be placed completely around the conductor and is closed in order to sense current properly.

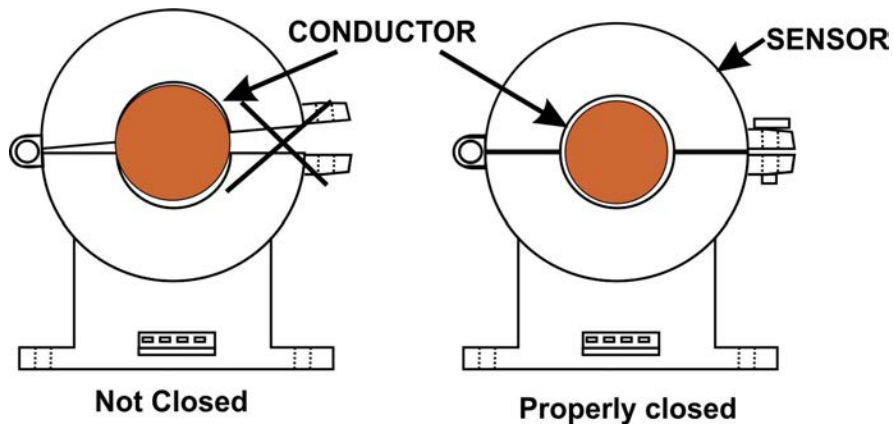

Hall Effect Sensors Available

MODEL	RATING	LOOP DIAMETER
E-AMP10-6-5	10A	0.26" (6.5mm)
E-AMP20-6-5	20A	0.26" (6.5mm)
E-AMP50-6-5	50A	0.26" (6.5mm)
E-AMP50-SC12	50A	0.47" (12MM)
E-AMP100-SC12	100A	0.47" (12MM)
E-AMP200-SC12	200A	0.47" (12MM)
E-AMP300-SC12	300A	0.47" (12MM)
E-AMP400-SC12	400A	0.47" (12MM)
E-AMP30-SC21	30A	0.83" (21MM)
E-AMP50-SC21	50A	0.83" (21MM)
E-AMP100-SC21	100A	0.83" (21MM)
E-AMP200-SC21	200A	0.83" (21MM)
E-AMP500-SC21	500A	0.83" (21MM)

3. Connect a 18-24AWG CAT5/5e/6 patch cable (up to 1,000 feet long) between the “Cat x” port on the E-DCLM-6 and an “RJ45 Sensor” port on the SYSTEM. (The use of smaller gauge CATx cabling will result in shorter distances that can be spanned.)

Note: If a CATx cable longer than 50 feet is used to connect the E-DCLM-6 to the E-2D/5D/16D, then 12VDC jack will need to be used to power the E-DCLM-6.

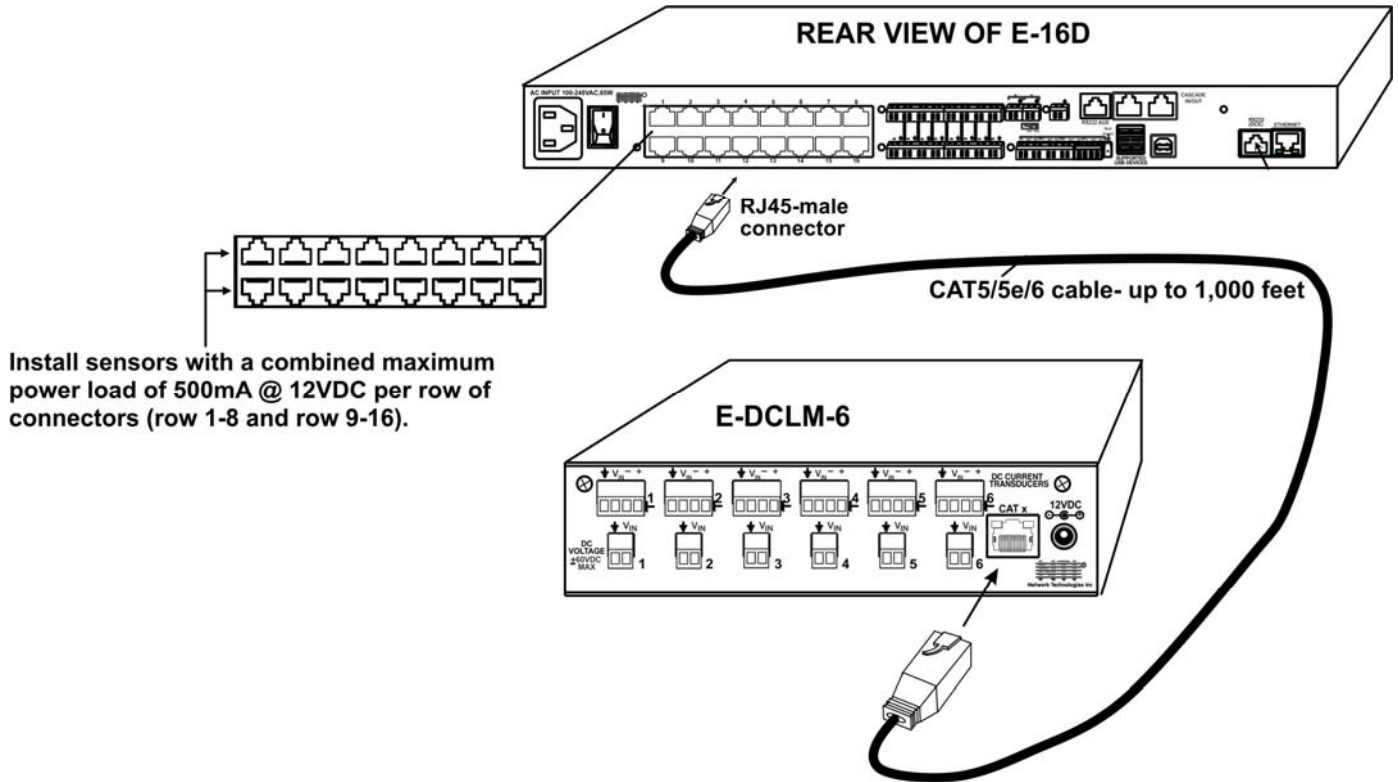

4. Configure the SYSTEM to react to changes in the voltage and/or current from the source(s), as desired. See examples on the following pages.

CONFIGURATION

Sensors					
Conn.	Description	Type	Value	Status	Action
5	Sensor #5.1a	DC Voltage	-0.1V	Normal	View Edit Delete
5	Sensor #5.1b	DC Current	0.2%	Normal	View Edit Delete
5	Sensor #5.2a	DC Voltage	0.0V	Normal	View Edit Delete
5	Sensor #5.2b	DC Current	0.2%	Normal	View Edit Delete
5	Sensor #5.3a	DC Voltage	0.0V	Normal	View Edit Delete
5	Sensor #5.3b	DC Current	0.4%	Normal	View Edit Delete
5	Sensor #5.4a	DC Voltage	-0.1V	Normal	View Edit Delete
5	Sensor #5.4b	DC Current	-20.7%	Normal	View Edit Delete
5	Sensor #5.5a	DC Voltage	0.0V	Normal	View Edit Delete
5	Sensor #5.5b	DC Current	0.2%	Normal	View Edit Delete
5	Sensor #5.6a	DC Voltage	-0.1V	Normal	View Edit Delete
5	Sensor #5.6b	DC Current	0.2%	Normal	View Edit Delete

When an E-DCLM-6 is connected to the ENVIROMUX, the summary page (above) will update with 6 sets of 2 different sensor types, DC Voltage and DC Current. The sensor is plugged into RJ45 Sensor port #5 in this example. Numbers “1a”, “2a”, “3a” and so on correspond to numbers 1-6 on the E-DCLM-6 for connected DC Voltage sources. numbers “1b”, “2b”, “3b” and so on correspond to numbers 1-6 on the E-DCLM-6 for connected hall effect sensors. Click on the Sensor in the Description column (or “View” under Action) and display the status page for each sensor. (Below). In order to better define the sensor on the Summary Page, in SNMP traps, or in an MIB browser, click on the “Edit” link to open the sensor configuration page and configure the sensor.

Sensor #5.1a Status

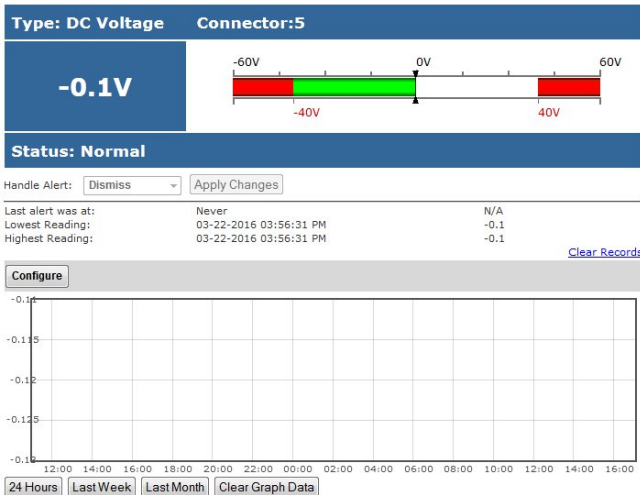

Sensor #5.1b Status

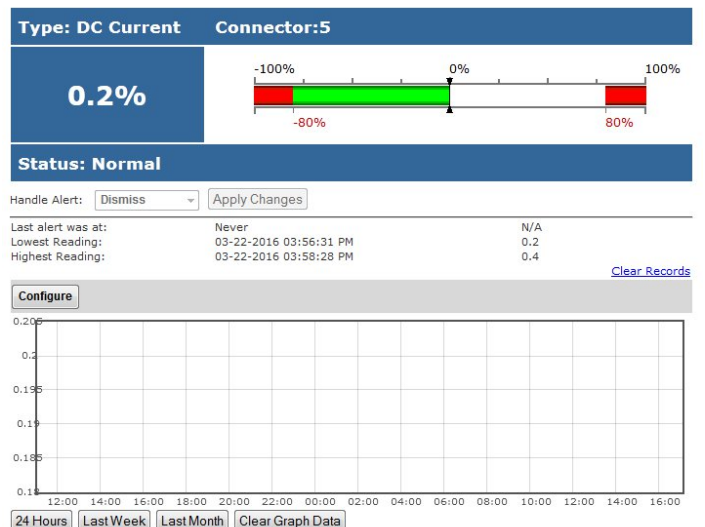

Click on the “Configure” button on any Status Page to display the Configuration page for any sensor.

Sensor #5.1a Configuration (Type: DC Voltage)

Sensor Settings	
Description	Sensor #5.1a Descriptive name for the sensor
Min. Level	-60.0 Min. supported value for the sensor
Max. Level	60.0 Max. supported value for the sensor
Min. Non-Critical Threshold	-40.0 Min. threshold below which indicates a non-critical alert condition
Max. Non-Critical Threshold	40.0 Max. threshold above which indicates a non-critical alert condition
Min. Critical Threshold	-40.0 Min. threshold below which indicates an alert condition
Max. Critical Threshold	40.0 Max. threshold above which indicates an alert condition
Refresh Rate	10 Sec The refresh rate at which the sensor view is updated
Group Settings	
Schedule Settings	
Non-Critical Alert Settings	
Critical Alert Settings	
Data Logging	
<input type="button" value="Save"/>	
Alert Simulation	
<input type="button" value="Simulate Alert"/> <input type="button" value="Clear Alert"/>	

Sensor #5.1b Configuration (Type: DC Current)

Sensor Settings	
Description	Sensor #5.1b Descriptive name for the sensor
Sensor Unit	% Measurement unit
Nominal Range	100.000000 Hall-Effect transducer rated current
Min. Non-Critical Threshold	-80.0 Min. threshold below which indicates a non-critical alert condition
Max. Non-Critical Threshold	80.0 Max. threshold above which indicates a non-critical alert condition
Min. Critical Threshold	-80.0 Min. threshold below which indicates an alert condition
Max. Critical Threshold	80.0 Max. threshold above which indicates an alert condition
Refresh Rate	10 Sec The refresh rate at which the sensor view is updated
Group Settings	
Schedule Settings	
Non-Critical Alert Settings	
Critical Alert Settings	
Data Logging	
<input type="button" value="Save"/>	
Alert Simulation	
<input type="button" value="Simulate Alert"/> <input type="button" value="Clear Alert"/>	

The default Unit and Range are “%” and “100” because at these values, ANY hall-effect sensor that is connected will be reported accurately on the summary page, regardless of its actual range.

If the Range value is changed to anything except “100”, the Unit must be also changed to “A” or “Amps” in order for the displayed value to be accurate. (The Nominal Range value must always be a positive number.)

We show the minimum threshold values here as negative because with DC current sensing, the reported values can be negative. (This is **not** true of AC current sensing.)

The numerical values of the thresholds (positive or negative) must always be equal to or less than the value of the Nominal Range.

Most of the sensor settings are the same as any other sensor configuration (page 39 of the E-xD manual) but for the DC Current Sensors there are some differences:

Sensor Settings	Description
Sensor Unit	<p>The default Sensor Unit is “%”. When a sensor value report that is a percent of its full scale is desired, use this unit. The value of all hall effect sensors will be reported accurately with this setting, regardless of their nominal range.</p> <p>Note: If the Nominal Range (below) is changed from the default “100”, the Sensor Unit must be changed to “A” or “Amps” to properly represent the value reported on the sensor Status and Summary pages.</p>
Nominal Range	<p>The default Nominal Range value is “100”. When combined with the default Sensor Unit of “%”, this value will allow the ENVIROMUX to report accurately any hall effect sensor that is connected, regardless of its range.</p> <p>However, if you wish to have the value on the sensor Status or Summary page reported in an accurate range of amperage, change this value to the maximum capacity of the connected hall effect sensor and be sure to change the Sensor Unit value (above) to “Amps”.</p>

TECHNICAL SPECIFICATIONS

Description	Specification
Polling rate	1Sa/s
DC Voltage Range	Non-isolated -60 to +60V DC
DC Reporting Accuracy	1.2VDC
DC Resolution	0.12VDC
Current Measurement	Requires Hall-Effect transducer (sold separately)
Power	12VDC from AUX PWR or AC Adapter or CATx cable from ENVIROMUX Sensor port
Voltage Range	Absolute maximum 10.8VDC to 16.5VDC
Current Draw	34mA (without load) + 26mA per Hall Effect Sensor Connected (190mA Maximum)
Operating Temperature	32 to 158°F (0 to 70°C)
Size (In.) W x D x H	6.83 x 3.0 x 1.75
Regulatory Approvals	CE, RoHS

COPYRIGHT

Copyright © 2009-2020 Network Technologies Inc. All rights reserved. No part of this publication may be reproduced, stored in a retrieval system, or transmitted in any form or by any means, electronic, mechanical, photocopying, recording, or otherwise, without the prior written consent of Network Technologies Inc, 1275 Danner Drive, Aurora, OH 44202.

CHANGES

The material in this guide is for information only and is subject to change without notice. Network Technologies Inc reserves the right to make changes in the product design without reservation and without notification to its users.

WARRANTY INFORMATION

The warranty period on this product (parts and labor) is two (2) years from date of purchase. Please contact Network Technologies Inc at (800) 742-8324 or 330-562-7070 for information regarding repairs and/or returns. A return authorization number is required for all repairs/returns.

MAN257 Revised 8/13/20